

LEADWELL
LEADWELL CNC MACHINES MFG., CORP.

LTC-35

CNC TURNING CENTERS

The Ultimate in Performance

LEADWELL CNC MACHINES MFG., CORP

NO.23, Gong 33th Road, Taichung Industrial Park

Taichung 407, Taiwan

TEL: 886-4-23591880

FAX: 886-4-23592555, 23593875

E-mail: sales@leadwell.com.tw

www.leadwell.com.tw

※ All performance are based on 220V/3PH/60HZ. Specification are subject to change without notice.



Saves Time! Saves Costs!

NEW!

LTC-35

Innovative New Design to Outperform Previous Models

A medium-size 45 degree slant bed CNC turning center with box ways on all axes.

◆ MORE POWERFUL

- Extra powerful spindle motor - 30 KW / 40 HP
- Also available - high torque option motor and gear box drive (37 KW/ 49 HP)
- Tubular design with crossed ribs for extra rigidity
- New motor mount to reduce vibration for increased production

◆ INCREASED CAPACITY

- Standard 12 inch chuck with increased through hole size for 3.5 inch bar capacity
- Optional 15 inch chuck with 4.5 inch bar capacity
- Max turning diameter now 600 mm and max swing diameter 720 mm
- Note: Suitable for machining 20 inch automotive wheels!
- Z-axis available from 1,100 mm (43 inches) to 4,100 mm (161.4 inches) - excellent for cutting long parts

◆ FASTER/MORE PRODUCTIVE

- Increased feedrate: X-15 M/min, Z-20 M/min
- 12 tool turret indexing time now 1.1 seconds

◆ NEW ERGONOMIC CONSIDERATIONS

- Double pivoting operator panel for easy access to machine
- Quieter, due to wide angle drive belt
- Lubrication oil is separated from coolant
- Built-in way cover wash

CNC TURNING CENTER

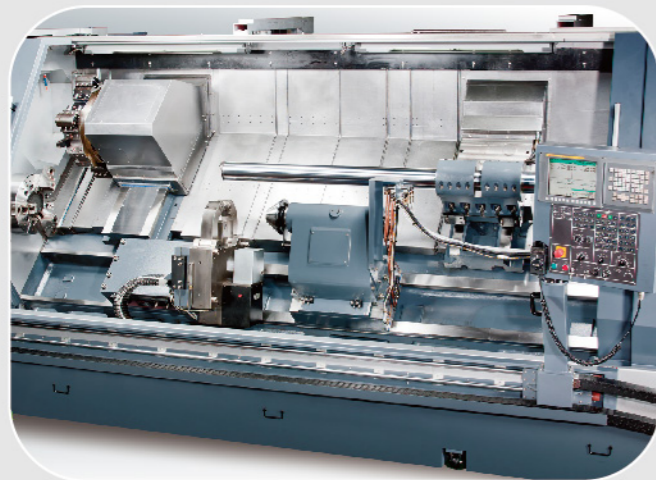
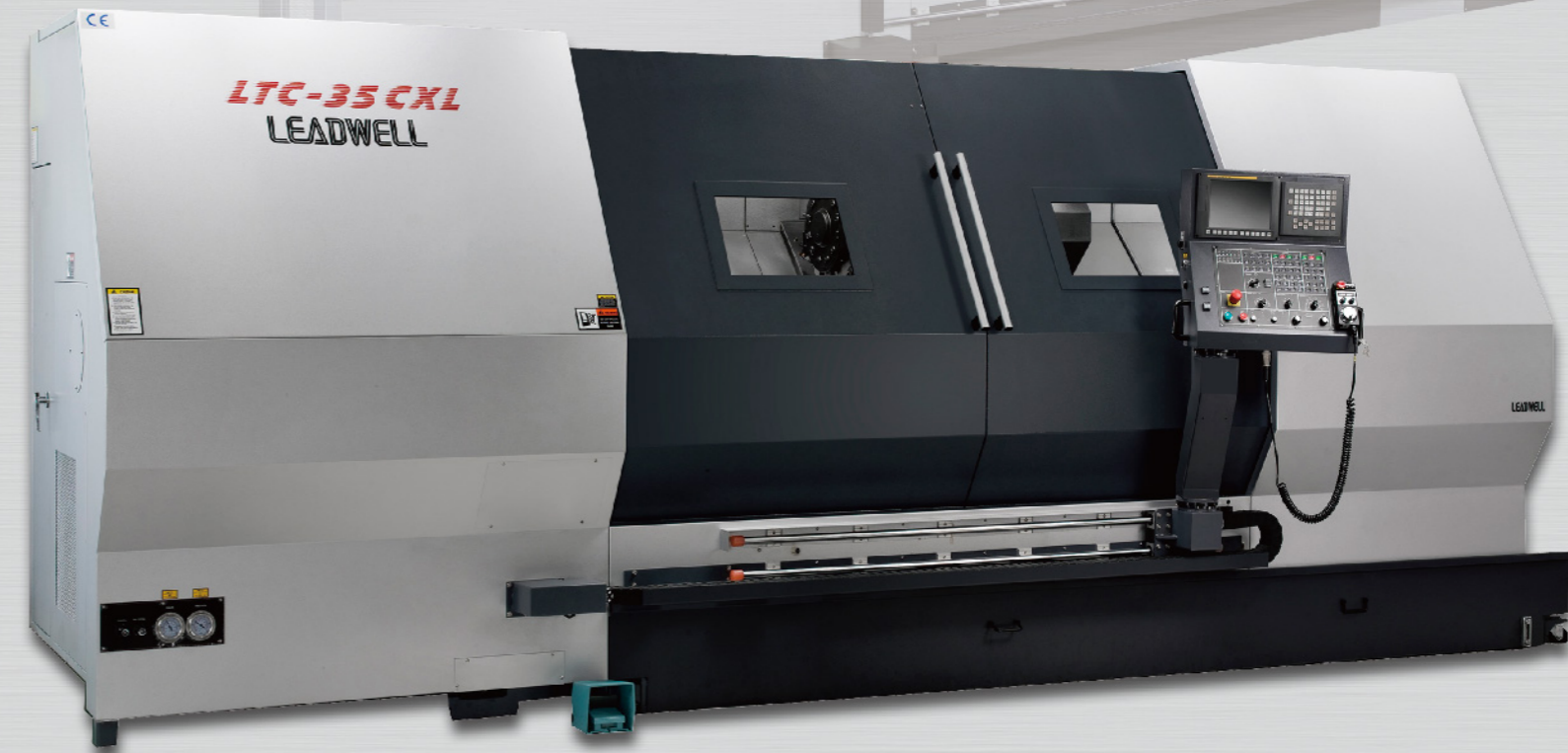

LEADWELL LTC SERIES FOR PRODUCTIVITY AND PROFITABILITY

LEADWELL's new LTC-35 series slant bed CNC turning centers are engineered for speed, precision, and enhanced productivity. You can depend on LEADWELL's LTC series to operate reliably year after year. The rigid construction provides superior stability for heavy metal removal and excellent workpiece accuracy. LEADWELL turning centers will help keep your business competitive and profitable.

LEADWELL Guarantees Superior Stability and Accuracy

Superior Slant Bed Construction

LEADWELL turning centers are of rigid cast iron construction to give a superior machining accuracy for years to come. The 45-degree slant bed allows for a stronger frame with easy access to the workpiece.

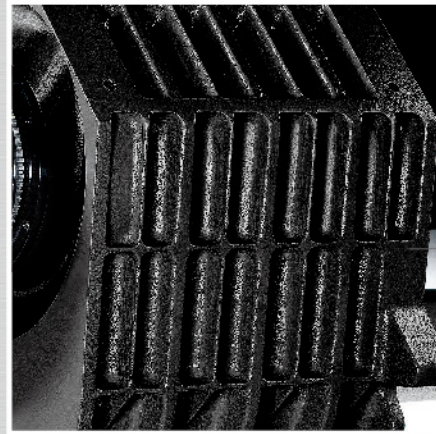

Headstock

The headstock is a thermally symmetric design with heat dissipating fins. This design prevents thermal distortion during long machining cycles.

Extra Wide Span for Increased Stability

The LTC series utilizes oversized box ways for high horse power machining. The extremely rigid base frame in combination with the box ways provide outstanding stability for precision turning.

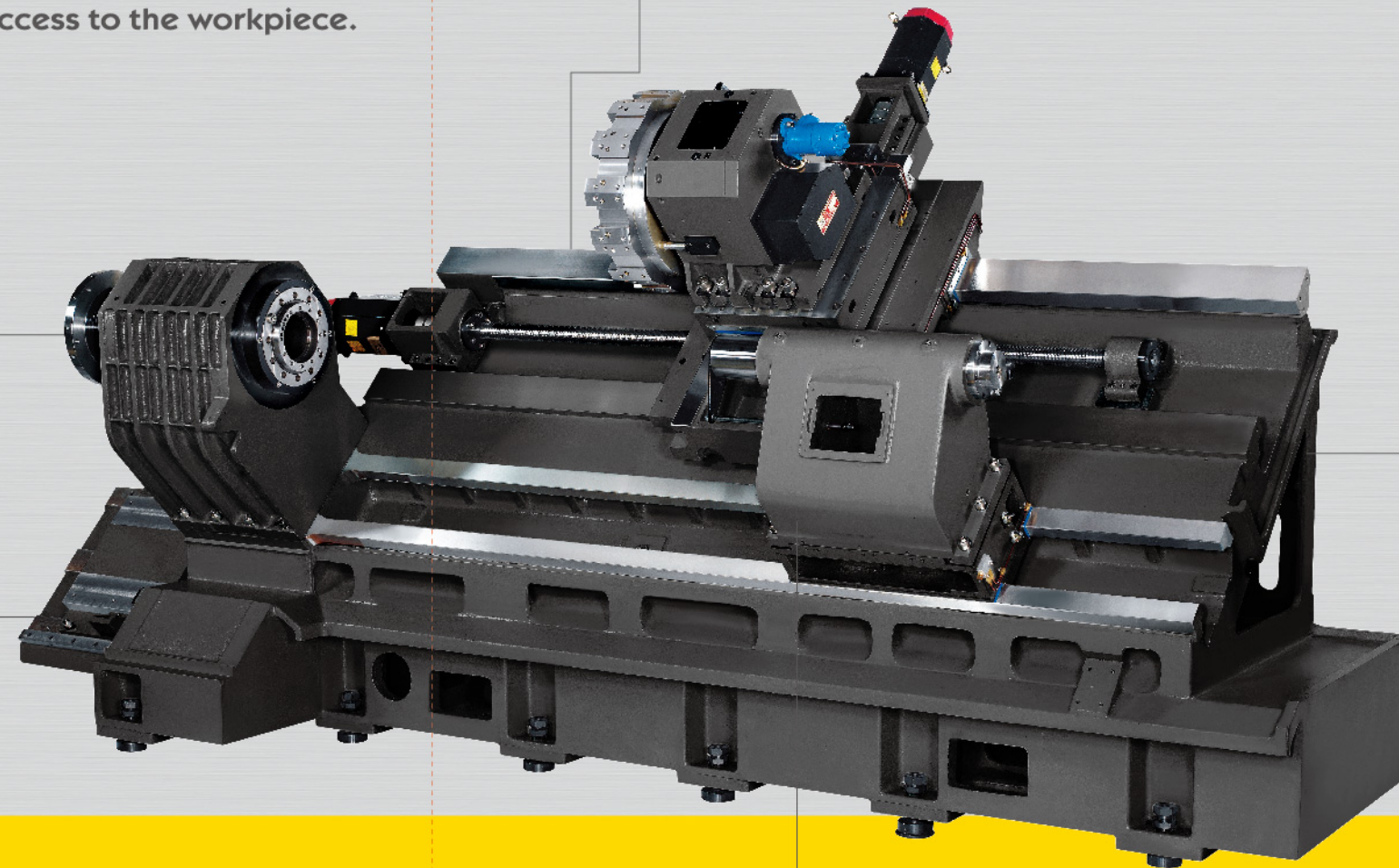

Easy Chip Disposal

- The 45-degree slant bed design allows chips to fall directly into the chip tank, avoiding accumulation inside the machine.
- The chip tank has large wheels, making it easy to move for chip removal and cleaning.
- An optional chain-type chip conveyor is available on all models.

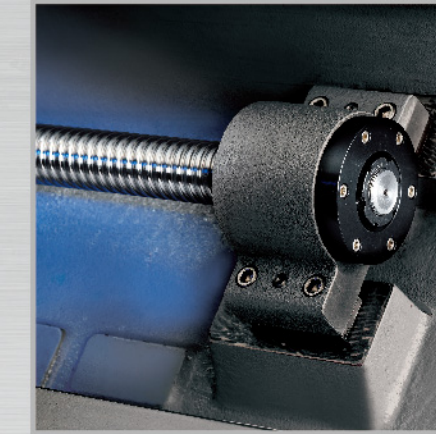

Pretension

The ball screws on all LEADWELL lathes are anchored at each end for extra rigidity and aligned parallel to the guide ways for highest accuracy. The ball screws are then stretched to apply tensioning for maximum stiffness and reduced thermal growth.

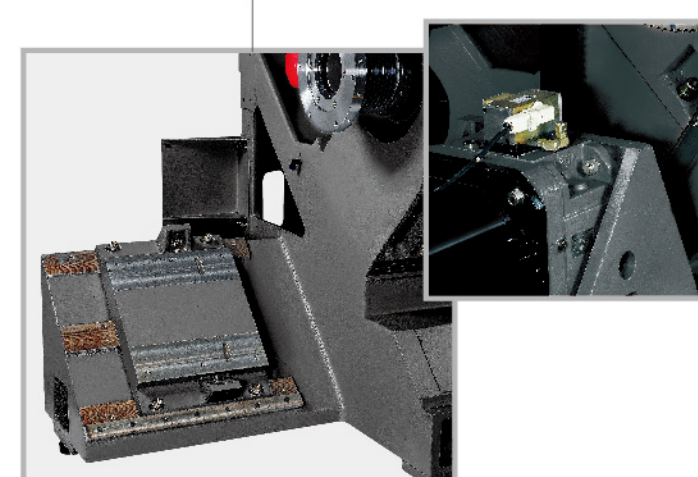

Cast Iron Construction Advantages

- LEADWELL uses only top quality well-ribbed castings.
- Advanced Finite Elements Analysis (FEA) is used for analyzing new casting to determine the size and location of all internal ribs, ensuring high torsional stiffness and minimum vibration.
- The cast iron base, saddle, headstock, slide and tailstock are ruggedly constructed for superior stability and machining accuracy.
- Isolated gear box (opt.).

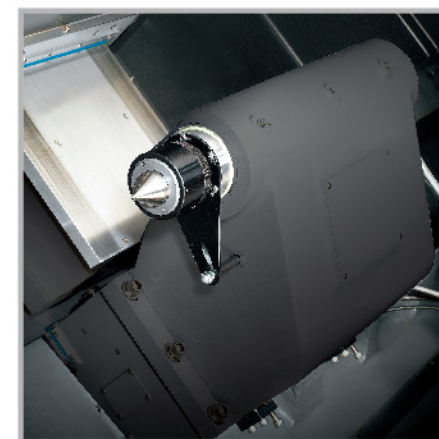

TRAVEL	LTC-35
X axis	300+20mm (12"+0.8")
Z axis	1100mm (43")/1600mm (63")/2100mm (83")/3100mm (122")/4100mm (161.4")

Rugged Tailstock

- The heavy-duty tailstock is attached to the lower guide of the machine base. The heavy casting, large diameter quill and precision morse taper center provide outstanding rigidity.
- The quill adjustment is hydraulic adding to the rigidity of the machine.
- An optional programmable tailstock is available on all models.

Item	LTC-35B Series	LTC-35C Series
Chuck Size	12"	15"
Chuck Each LEADWELL lathe comes with a 3-jaw hydraulic through hole chuck.		
Tool Station	12PCS (STD)	12PCS (OPT)
Turret The LTC series turret features a robust casting and a large coupling face adding extreme rigidity to the machine. This added rigidity provides increased metal removal rates, extends tool life, enhances finishing quality, and ensures long term accuracy. A reliable high torque hydraulic indexing motor controls turret rotation, deceleration and clamping. Turret indexing is bi-directional with 0.25 second station-to-station indexing time.		

Quality Features Guarantee Greater Performance



• LEADWELL uses only premium quality preloaded double-nut ballscrews. Each ball screw is accurately aligned parallel to the box ways and anchored at both ends.

• Ball screws are pretensioned to improve machine stiffness. The rotational torque variation is inspected to guarantee non-binding, highly accurate, and long running components. This assures lifetime accuracy and maximum service life.

HIGH CHIP REMOVAL RATE-EASIER THAN EVER!

When your operations require higher efficiency to stay competitive, LEADWELL's LTC-35 can help you.

CUTTING TEST RESULTS

O.D. TURNING

Cutting Feedrate M/min.	Cutting Depth mm.	Feedrate mm/rev.	Chip Removal Rate c.c./min.	Workpiece Material
180	11	0.35	1054.7	S45C

SLOT TINGON O.D.

Cutting Feedrate M/min.	Slot Width mm.	Feedrate mm/rev.	Distance from Chuck Face	Workpiece Material
103.2	3	0.2	300 mm	S45C

DRILLING

Cutting Feedrate M/min.	Hole Dia. mm.	Feedrate mm/rev.	Spindle Speedrpm	Workpiece Material
77.4	70	0.15	516	S45C

HIGH PRODUCTIVITY OPTIONS

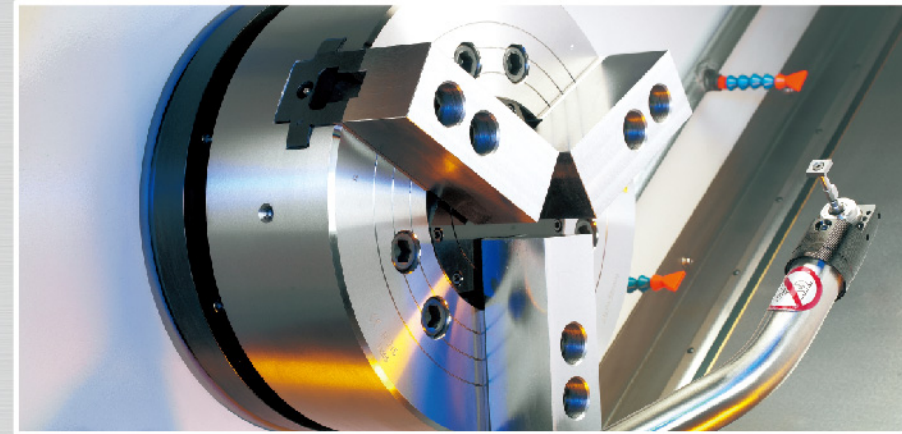

Tool Setter (OPT)

The tool setter has a touch sensor that can measure varying tool lengths and detect broken tools. It can be easily programmed to store all the tool information to reduce tool changing time.

Double Chuck (OPT)

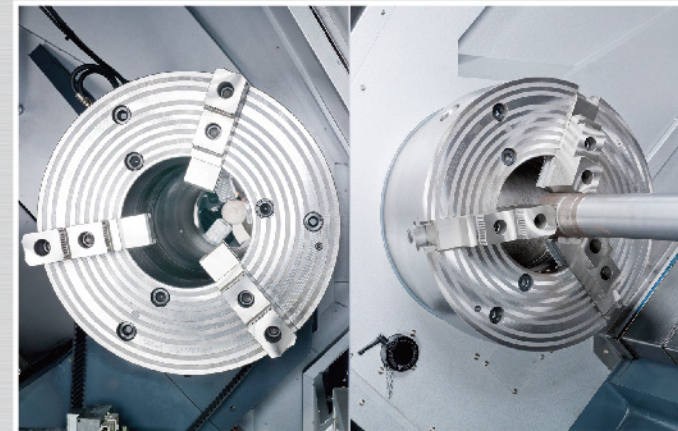

Security Auto Door (OPT)



FANUC 0i

- Controlled axis
- Simultaneously controlled axes
- Least input increment
- Emergency stop
- Mirror image
- Follow up
- Servo off
- Backlash compensation
- Stored pitch error compensation
- DNC operation
- Manual reference position return
- Exact stop
- Rapid traverse override
- Automatic acceleration / deceleration
- Override cancel
- Tape code: EIA RS244/ISO 840
- Label skip
- Optional block skip
- Decimal point programming
- Rotary axis designation
- Automatic coordinate system setting
- Workpiece coordinate system
- Programmable data input
- Rigid tapping
- Tool function
- Cutter compensation C
- Canned cycles
- Background editing
- Status display
- Clock function
- Self-diagnosis function
- Alarm display
- Part program storage length: 640M
- Multi language display
- Data service & CF card
- 8.4" color TFT
- 10.4" color TFT(OPT)



Live Tooling Option

The live tooling option turns the turret into multiple auxiliary spindles. The turret spindle supports milling, drilling, and tapping.

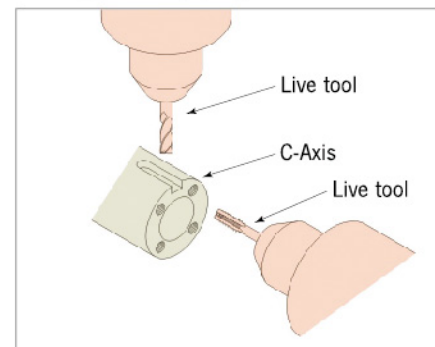

C-Axis Option

The headstock spindle becomes a fully programmable servo axis with the C-Axis option.
• C Axis index resolution: 0.001 degrees

By synchronizing the optional C Axis with the live tooling, machining of cylindrical cams and other complex work pieces becomes easy, saving time and money for each part. Switching between normal turning & synchronization with live tooling takes less than 1 second.

•Live tooling available on the following models

MODEL	LTC-35M
Rotary tool speed RPM	3000
Spindle (kW)	15 kW

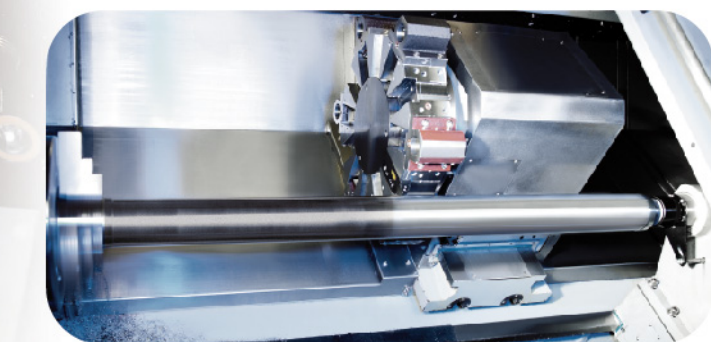

Precision Rigid Spindle

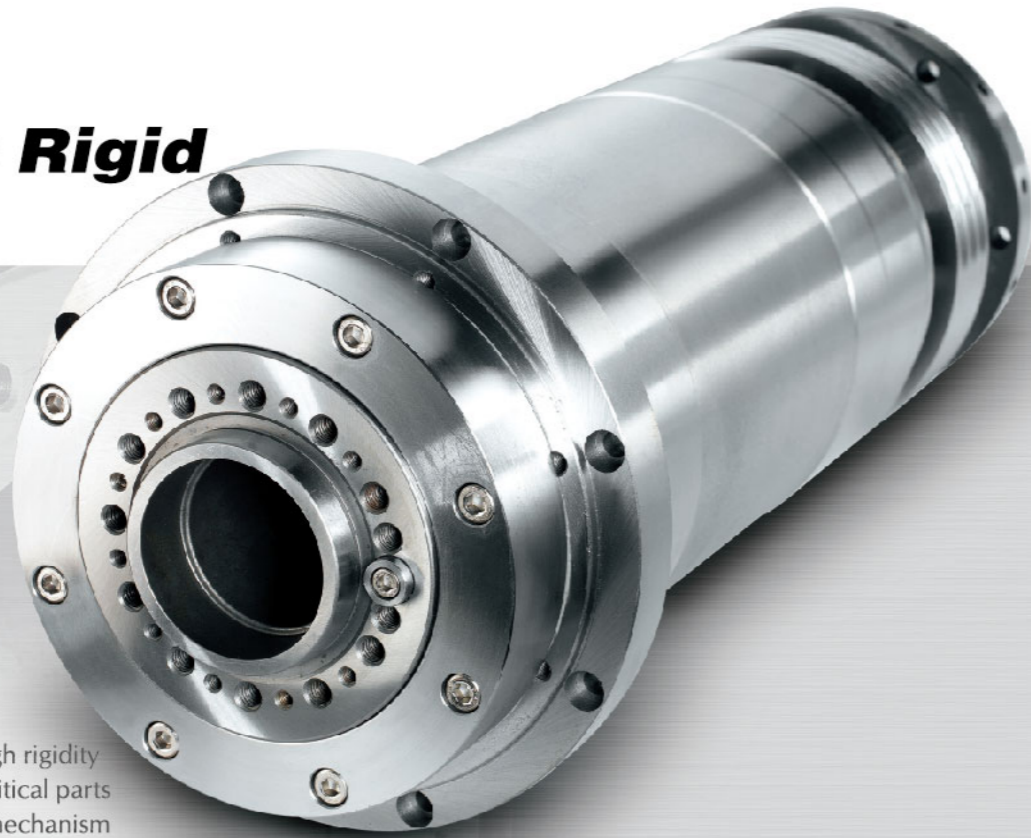

- Air jet around spindle nose
- Wide bearing spacing for high rigidity
- Special heat treatment for critical parts
- Highly accurate draw tube mechanism
- Precision Labyrinth seal
- Large diameter quill for high rigidity
- Optimum spacing of front bearings to spindle nose for highest rigidity

SPINDLE SPEED/OUTPUT DIAGRAM

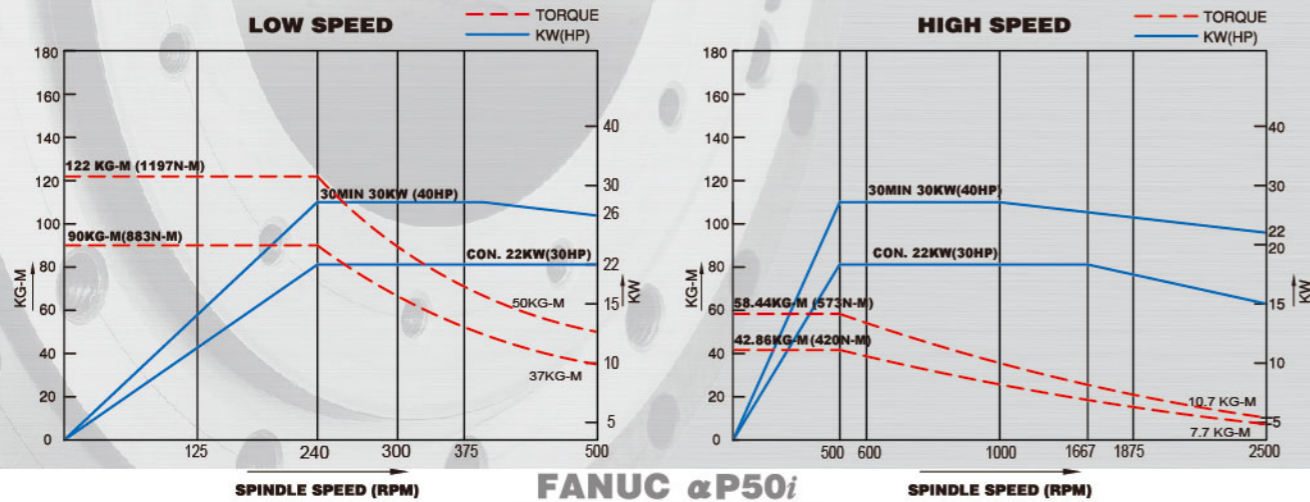

FANUC alphaP50i
LTC-35B (CHUCK 12")

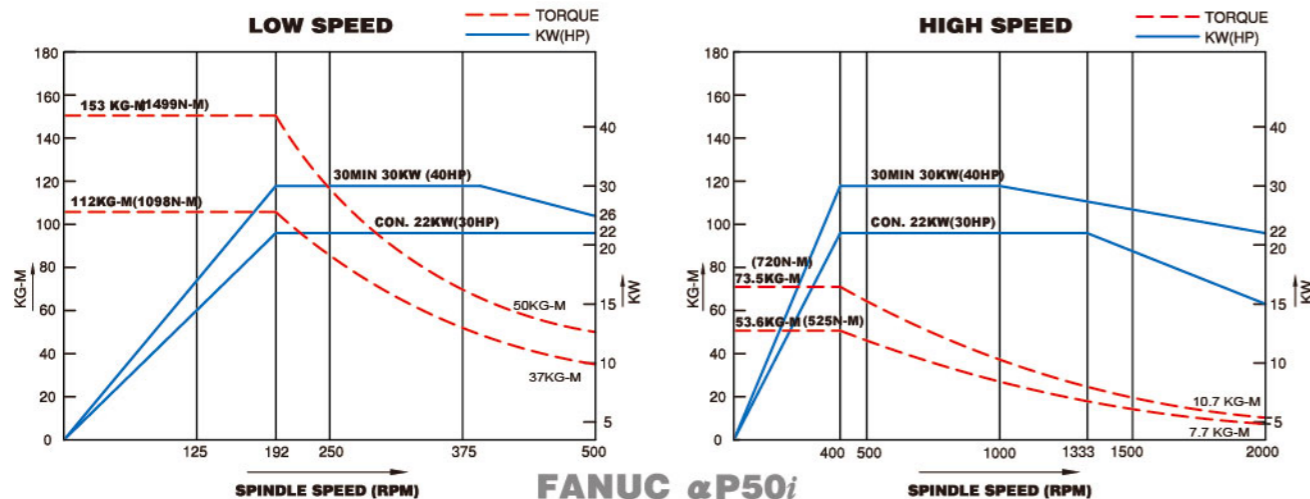

FANUC alphaP50i
LTC-35C (CHUCK 15")

Heavy Duty Turret

The LTC series turret features a robust casting and a large coupling face adding extreme rigidity to the machine. This added rigidity provides increased metal removal rates, extends tool life, enhances finishing quality, and ensures long term accuracy. A reliable high torque hydraulic indexing motor controls turret rotation, deceleration and clamping. Turret indexing is bi-directional with 1.7 second station-to-station indexing time.

TOOLING SYSTEM

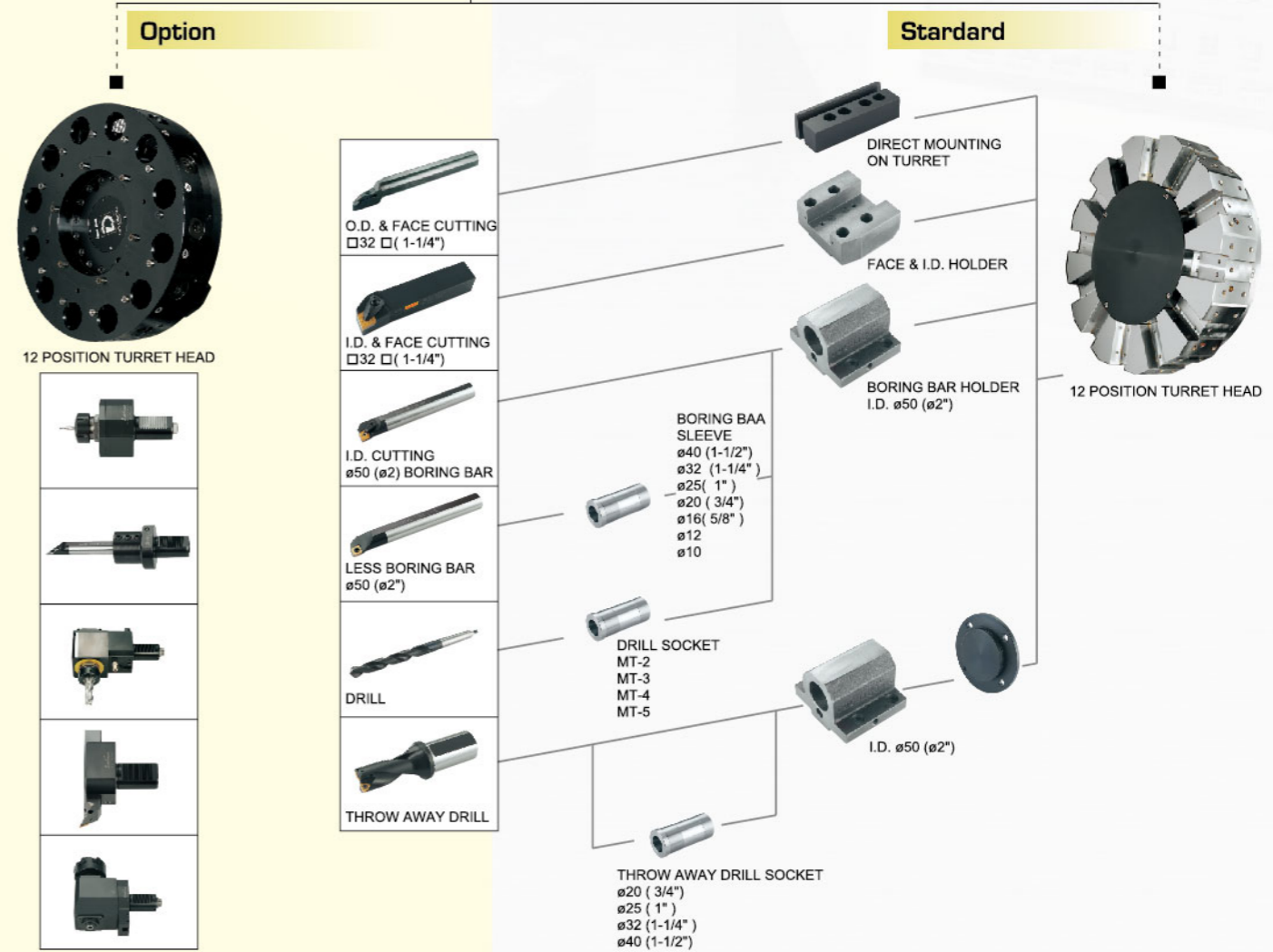

TOOLING INTERFERENCE

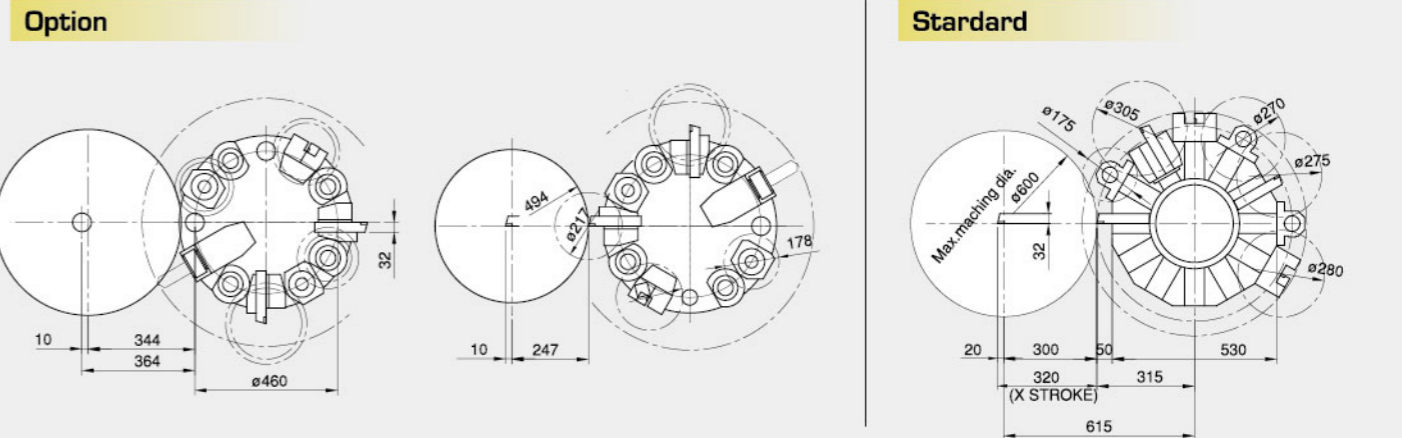

MACHINE DIMENSIONS

MODE	A	B	C
LTC-35B/C	4380	4600	5530
LTC-35BL/CL	4880	5100	6030
LTC-35BXL/CXL	5380	5600	6530
LTC-35BXXL/CXXL	6380	6600	7530
LTC-35BLV/CLV	7880	8100	9030

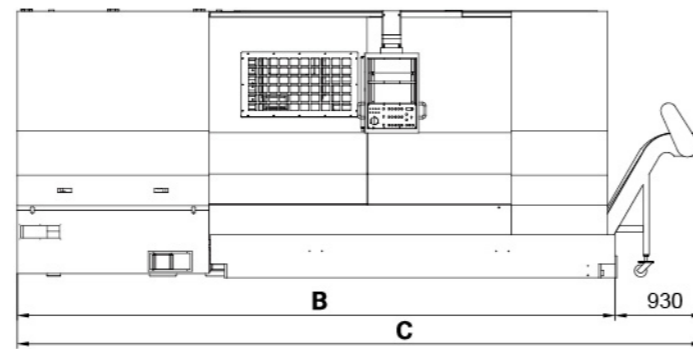
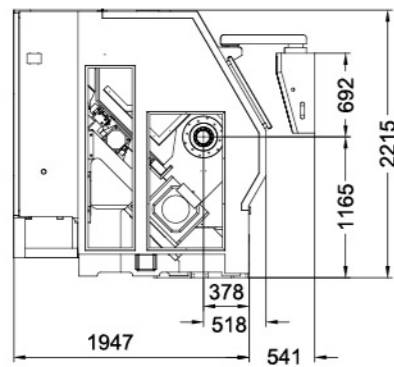
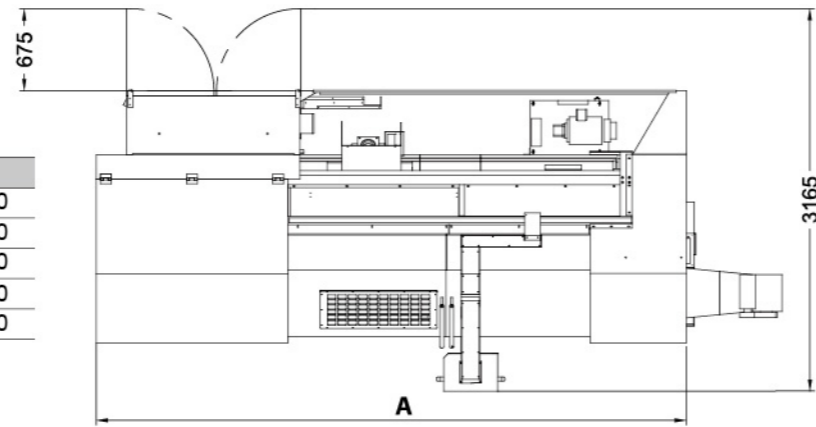

WORKING CAPACITY

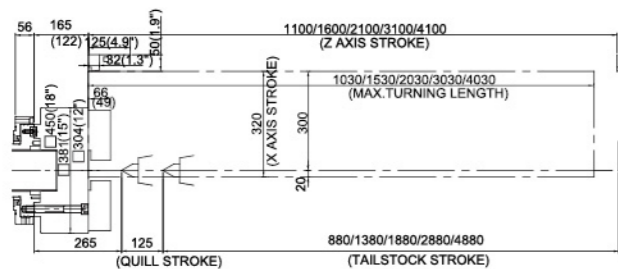

LTC-35 CUTTING RANGE

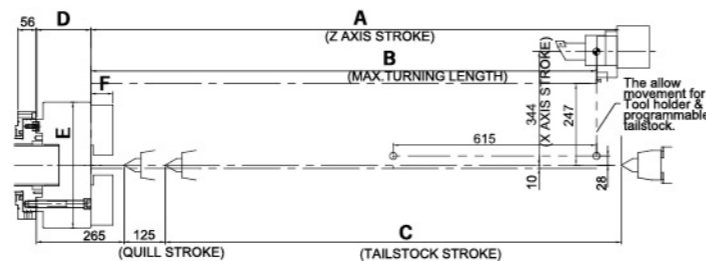

LTC-35M CUTTING RANGE

MODE	A	B	C	D	E	F
LTC-35B	1100(43.3")	1030(40.6")	880(34.6")	122(4.8")	304(12")	49(1.9")
LTC-35C	1100(43.3")	1030(40.6")	880(34.6")	165(6.5")	381(15")	66(2.6")
LTC-35BL	1600(63")	1530(60.2")	1380(54.3")	122(4.8")	304(12")	49(1.9")
LTC-35CL	1600(63")	1530(60.2")	1380(54.3")	165(6.5")	381(15")	66(2.6")
LTC-35BXL	2100(82.7")	2030(80")	1880(74")	122(4.8")	304(12")	49(1.9")
LTC-35CXL	2100(82.7")	2030(80")	1880(74")	165(6.5")	381(15")	66(2.6")
LTC-35BXXL	3100(122")	3030(119.3")	2880(113.4")	122(4.8")	304(12")	49(1.9")
LTC-35CXXL	3100(122")	3030(119.3")	2880(113.4")	165(6.5")	381(15")	66(2.6")

ITEM	MODEL	Unit	LTC-35B/BL/BXL	LTC-35C/CL/CXL	LTC-35BXXL/BLV	LTC-35CXXL/CLV
CAPACITY						
Max. swing	mm (in)		720 (28.3)			
Swing over cross slide	mm (in)		540 (21.3)			
Max. turning diameter	mm (in)		600 (23.6)			
Max. turning length	mm (in)		1030/1530/2030	1030/1530/2030	3006/4006	3006/4006
Bar capacity	mm (in)		90 (3.5")	115 (4.5")	90 (3.5")	115 (4.5")
Max. workpiece weight (w/o tailstock)	kg (lb)		700	1200	700	1200
TRAVEL						
X axis	mm (in)		300 (11.8") + 20 (0.7")			
Z axis	mm (in)		1100/1600/2100		3100/4100	
SPINDLE						
Spindle speed range	rpm		2500	2000	2500	2000
Chuck size			A2-8	A2-11	A2-8	A2-11
Hole through spindle	mm (in)		127 (5")			
Spindle power	kW (HP)		30 (40)			
Spindle torque	Nm/ft-lb		240	192	240	192
TURRET						
Number of tool stations			12			
Shank height for square tools	mm (in)		32 (1.25)			
Shank diameter for boring tools	mm (in)		50 (2) / OPT 63 (2.5)			
Index time (adjacent tools)	sec		1.7			
Index time (180)	sec		4.5			
FEEDRATE						
X axis rapid traverse	M/min		15			
Z axis rapid traverse	M/min		20		12 (B(C)XXL) / 10 (B(C)LV)	
TAILSTOCK						
Quill movement type			Auto			
Quill stroke	mm (in)		125 (4.9)			
Quill diameter	mm (in)		110 (4.3)			
Quill inside taper	M.T.		5			
MACHINE SIZE						
Power requirement	KVA		55			
Machine length	mm		4380/4880/5380		6380/7880	
Machine width	mm		2090		2320	
Machine height	mm		2192		2320	
Total machine weight	kg		8700/9400/10100	8800/9500/10200	17000/19500	17000/19500

STANDARD ACCESSORIES

- RS232 interface
- Fully enclosure guarding
- Work light
- Metric or inch tool disc
- Heat exchanger
- Leveling screws and pads
- Maintenance tool box
- Buzzer
- 3 jaw open center chuck
- Chuck foot switch
- Programmable tailstock
- Wide angle v-belt

OPTIONAL ACCESSORIES

- VDI tool disc
- Tool setter
- Status lights
- Tool tip air blow system
- High pressure coolant
- Oil mist collector
- Chip conveyor
- Chip bucket
- Manual steady rest
- Auto steady rest with hydraulic
- Linear scales
- Oil skimmer
- Transformer
- HTD belt
- Second coolant system
- Air conditioner in cabinet
- 2 speed gearbox